

MODEL AF-10EN

FULL BORE SAFETY VALVE

PRODUCT MANUAL

Thank you very much for choosing the Yoshitake's product. To ensure the correct and safe use of the product, please read this manual before use. This manual shall be kept with care for future references. The symbols used in this manual have the following meanings.



	Warning	This symbol indicates a potentially hazardous situation that, if not avoided, may result in death or serious injury.
	Caution	This symbol indicates a potentially hazardous situation that, if not avoided, may result in minor or moderate injury or may result in only property damage.

Table of Contents

1. Specifications.....	1
2. Dimensions and structure	2
3. Operation	3
4. Nominal size selection table	4
5. Installation	5
6. Precautions for use	7
7. Maintenance	8
7.1 Daily inspection	8
7.2 Periodic inspection	8
7.3 Troubleshooting.....	9
Warranty Information	

YOSHITAKE

1. Specifications

Model		AF-10EN
Structure		Open type with lever ^{*1}
Nominal size		20A-100A
Application		Steam, Air, Other non-dangerous gases
Working pressure		0.1-1.6 MPa ^{*2}
Max. temperature		250 °C ^{*2}
Material	Body	Ductile cast iron
	Spring chamber	Ductile cast iron
	Valve and Valve seat	Stainless steel
Connection		EN PN16 flanged ^{*2} (Outlet is two sizes larger than inlet.)

*1: The structure in which the fluid is discharged from the outlet and other parts.

*2: The max. set pressure and the max. temperature are according to the PT rating. Please see below.

Pressure-Temperature Rating

PN16				
Temperature (°C)	-10 to 120	150	200	250
Max.set pressure(MPa)	1.6	1.55	1.47	1.39

Note: Intermediate values may be obtained by linear interpolation.

Temperature and max. set pressure

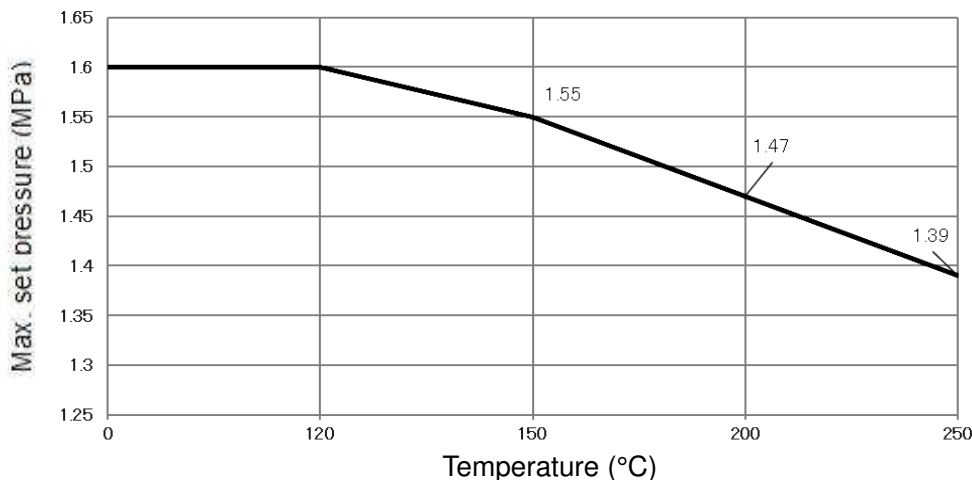

Caution

1. Please do not use this product for equipment or device which does not allow the valve seat leakage.
* The product has valve seat leakage within the allowable value, and it cannot be fully closed. The valve seat leakage cannot be zero.
2. Do not use the product for equipment or device which vibrates excessively.
* Failure to follow this notice may result in malfunction.
3. Do not adjust or change the set pressure.
* Failure to follow this notice may result in damage to the equipment.
4. Please confirm that the indications on the product correspond with the specifications of the ordered product model before use.
* If they are different, please contact us without using the product.

2. Dimensions and structure

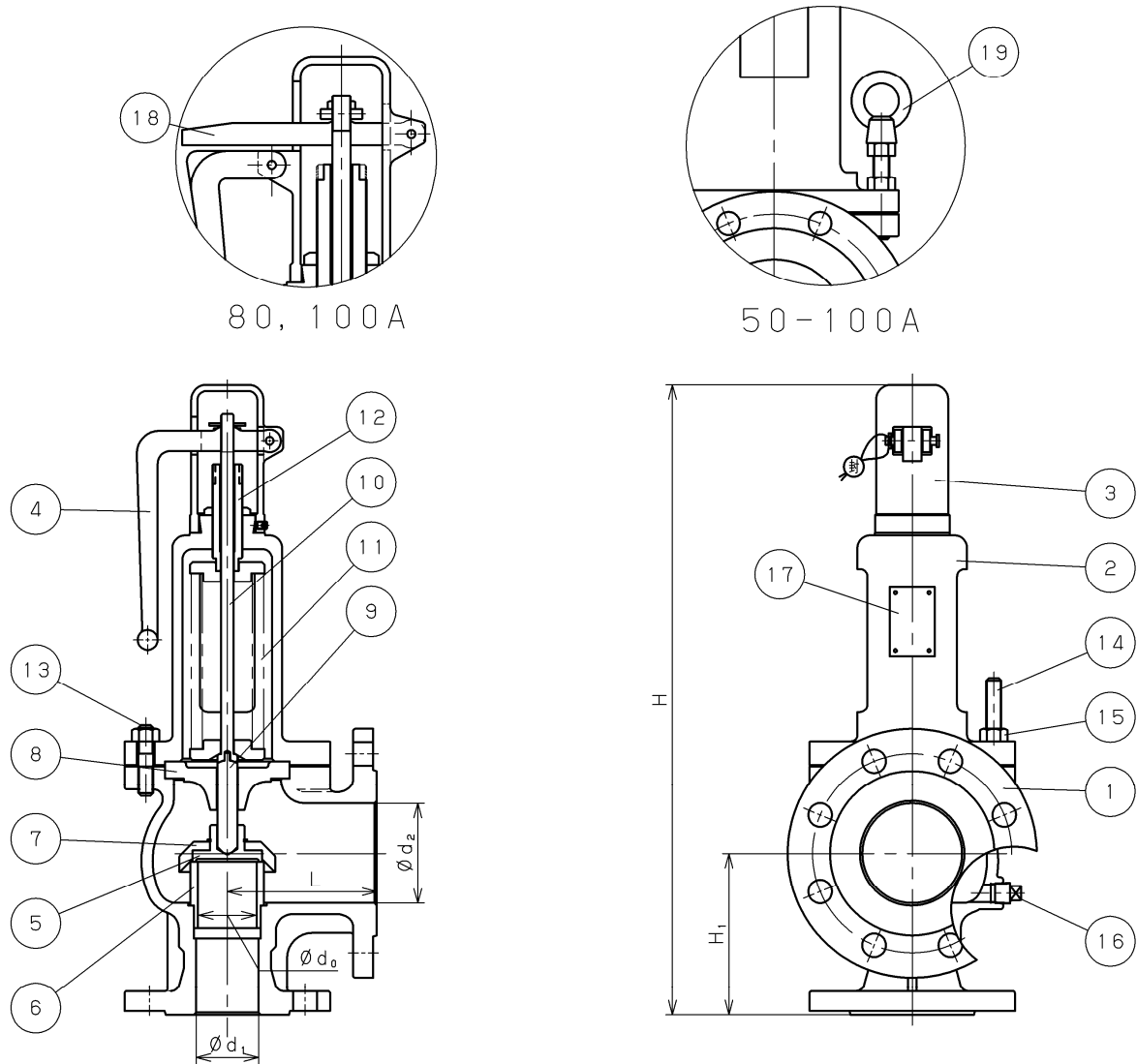

Figure 1

No.	Name of Parts	No.	Name of Parts
1	Body	10	Spindle B
2	Spring Chamber	11	Spring
3	Cap	12	Adjusting Screw
4	Lever	13,14	Stud Bolt
5	Valve	15	Hexagon Nut
6	Valve Seat	16	Square Head Plug
7	Valve Cover	17	Name Plate
8	Guide Plate	18	Lever Support
9	Spindle A	19	Eye Nut

(mm)

Nominal size	d ₁	d ₂	d ₀	L	H ₁	H	Flow area (mm ²)
20A	20	32	18.5	85	85	360	268
25A	25	40	23	100	100	375	415
32A	32	50	29.5	105	110	450	683
40A	40	65	36.5	115	125	470	1046
50A	50	80	46	120	130	510	1661
65A	65	100	59.5	140	160	680	2780
80A	80	125	73	160	180	785	4185
100A	100	150	91	180	200	895	6503

3. Operation

1. Initial closed state
The valve is closed by the spring force while the inlet pressure is lower than the set pressure.
2. Start to discharge
As the inlet pressure increases, the force pushing up the valve becomes closer to the spring force pushing down the valve, and the product starts to discharge.
3. Discharge
When the fluid pressure becomes larger than the spring force due to the increased inlet pressure and being supported by the valve cover, the valve opens.
4. Closing
After the fluid is discharged to the air, the inlet pressure decreases. The valve closes when the fluid pressure becomes smaller than the spring force.
5. Discharge by lever
Discharge check can be done by pulling up the lever when the inlet pressure is 80% of the set pressure or higher.

4. Nominal size selection table

● For Steam (Saturated steam temperature) EN ISO 4126-1:2013 (kg/h)

Nominal size	Pressure (MPa)							
	0.1	0.2	0.3	0.4	0.5	0.6	0.7	0.8
20A	224	338	451	564	676	787	899	1010
25A	348	524	699	873	1047	1219	1392	1564
32A	573	862	1151	1437	1723	2007	2291	2574
40A	877	1321	1762	2202	2639	3074	3509	3942
50A	1393	2098	2799	3497	4191	4882	5572	6259
65A	2332	3512	4684	5852	7015	8172	9326	10477
80A	3511	5286	7052	8811	10561	12302	14039	15772
100A	5457	8215	10959	13691	16411	19116	21815	24508

(kg/h)

Nominal size	Pressure (MPa)							
	0.9	1.0	1.1	1.2	1.3	1.4	1.5	1.6
20A	1120	1231	1341	1451	1560	1670	1780	1889
25A	1735	1906	2077	2246	2416	2586	2757	2926
32A	2856	3138	3418	3697	3977	4257	4537	4816
40A	4374	4806	5235	5663	6090	6520	6949	7376
50A	6946	7632	8313	8993	9671	10353	11035	11713
65A	11625	12774	13913	15051	16187	17328	18469	19604
80A	17501	19229	20945	22658	24368	26086	27803	29513
100A	27195	29881	32547	35208	37866	40535	43203	45859

● For Air (20°C) EN ISO 4126-1:2013 (kg/h)

Nominal size	Pressure (MPa)							
	0.1	0.2	0.3	0.4	0.5	0.6	0.7	0.8
20A	353	539	724	910	1095	1280	1466	1651
25A	548	835	1122	1409	1696	1983	2270	2557
32A	902	1374	1847	2319	2792	3264	3737	4209
40A	1381	2105	2828	3552	4276	4999	5723	6446
50A	2193	3342	4491	5641	6790	7939	9088	10237
65A	3671	5594	7518	9441	11364	13287	15211	17134
80A	5527	8422	11317	14212	17108	20003	22898	25793
100A	8588	13087	17586	22085	26584	31082	35581	40080

(kg/h)

Nominal size	Pressure (MPa)							
	0.9	1.0	1.1	1.2	1.3	1.4	1.5	1.6
20A	1837	2022	2208	2393	2578	2764	2949	3135
25A	2844	3132	3419	3706	3993	4280	4567	4854
32A	4682	5154	5627	6099	6572	7044	7517	7989
40A	7170	7894	8617	9341	10065	10788	11512	12235
50A	11386	12535	13684	14833	15982	17132	18281	19430
65A	19057	20980	22903	24827	26750	28673	30596	32520
80A	28689	31584	34479	37374	40269	43165	46060	48955
100A	44579	49078	53577	58076	62574	67073	71572	76071

5. Installation



Warning

1. Do not install any closing device such as a stop valve at the inlet or outlet side of the product.
* Failure to follow this notice may result in damage to equipment due to insufficient discharge caused by resistance from the closing device.
2. Connect a discharge pipe at the outlet side of the product, and lead it to a place where there is no risk of physical damage even if the fluid blows out.
* Failure to follow this notice may result in injury and scales in case fluid blows out.
3. Do not disassemble the product unless it is necessary.
* Unnecessary disassembly prevents the product from functioning properly and leads to danger.
4. Do not apply a viscous fluid that may make fixation of the valve and valve seat.
* Failure to follow this notice may result in malfunction due to the fixation of the valve and valve seat.



Caution

1. Before installation, clean the flange surfaces, and remove foreign substances and scale from piping.
* Failure to follow this notice may prevent the product from functioning properly.
* Please note that any repair due to foreign substances or scale is **subject to a charge** even during the warranty period.
2. Before connecting the product to piping, check the inlet and outlet of the product so that the fluid flow direction and the arrow marked on the product are in the same direction.
* Installing the product in a wrong position prevents it from functioning properly.
3. Install the product vertically with the cap [3] upward.
* Wrong installation prevents the product from functioning properly.
4. Pipe connections to the product should fulfill the requirements given in supervisory regulations.
Ensure that the piping can flow all the discharged fluid sufficiently. When the fluid is being discharged from several safety valves by means of one common pipe, the flow passage area of such common pipe has to be larger than the sum of the outflow cross-sections of the discharge pipes to be connected to each of the safety valve. Moreover, the pipe's curve should be gentle, and provide a drain pipe if there is a risk of rain water or condensate accumulation.
* Rain water or condensate accumulated in the discharge pipe causes malfunction due to rust, etc.
5. Give proper support to the outlet piping that is subjected to the reaction force against the exhaust flowing up through the exhaust pipe connected to the product.
* Excessive piping stress may deform the product resulting in malfunction.
6. When hot fluid is applied, install the outlet piping in a way that the product is free from the stress caused by the thermal expansion of the equipment or by the thermal expansion/compression of the discharge pipe. (See Figure 2.)
7. Securely connect the product to piping.
* Failure to follow this notice may cause fluid leakage from connections due to vibration.
8. Lead the discharge pipe to outside of buildings if there is a risk that fluid blowout causes alarm activation or contamination of the peripheral equipment.
* Failure to follow this notice may cause contamination of the peripheral equipment.
9. Place where the product is installed should be easily accessible, well-lit and protected from external factors. In case of installing the product on the outside area, it has to be protected from freezing and precipitations.
10. Inner diameter of pipe mount and that of discharge pipe should be equal to or larger than that of each inlet and outlet of the product.
* Failure to follow this notice causes malfunction or insufficient discharge.

1 Pipe mount

- 1.1 The pipe mount should have adequate strength to endure the reaction force, which is applied toward the opposite direction of the discharge and along with the center line of the discharge port.
- 1.2 Pressure loss in the pipe mount decreases the discharge capacity and destabilize the product operation. Install the product vertically at a position as close as possible to the boiler body or the header, as well as accessible for maintenance and inspections.
- 1.3 The inner diameter of the pipe mount should be equal to or larger than that of the product inlet.

2 Discharge pipe

- 2.1 Install a discharge pipe and drip pan elbow to ensure that the product is free from the stress caused by the thermal expansion of the equipment or by the thermal expansion/compression of the discharge pipe.
- 2.2 The inner diameter of the discharge pipe should be equal to or larger than that of the product outlet to avoid backpressure.

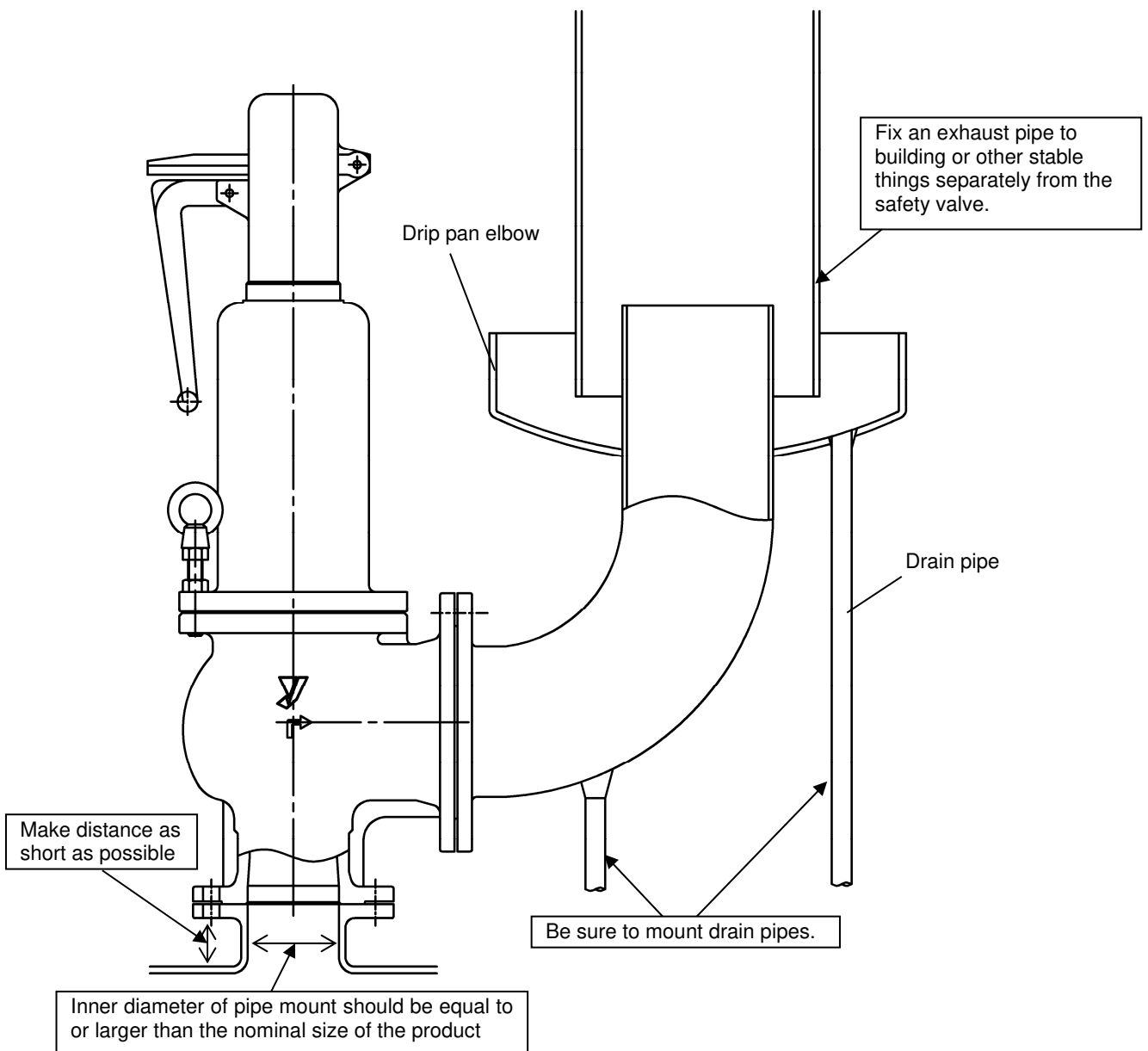

Figure 2 Piping example

6. Precaution for use



Warning

1. Do not touch the product, pipes, or the lever [4] with bare hands.
* Failure to follow this notice may result in scalds or injury in case that the fluid is hot.
2. Wear earplugs when checking the operation of the product, and do not stand in front of the discharge pipe. Do not look into the pipe or put your hands out to the pipe.
* The product makes a loud blowing noise during operation. Failure to follow this notice may cause scalds or injury due to blowout.
3. Do not disassemble the product.
* Please contact us if anything abnormal is noticed.



Caution

1. Checking the operation of the product depends on blowing through the product with using the lever [4]. Moving the lever causes loosening of spring pressure and thus allows minimum lift of valve and blow of fluid.
2. Make the inlet pressure 80% of the set pressure or higher before operating the lever. After blowing through the product by pulling up the lever, check that the lever has returned to the original position. In case of raising the fluid pressure, check beforehand that no problems will occur regarding the equipment installed onto the piping.
* Failure to follow this notice may damage the equipment.
3. If any leakage is observed after blowing through the product, there is a possibility that a foreign substance may be stuck between the sealing surfaces. In this case, blow through the product once again to remove it. If there remains a leakage despite of this action, please contact us.

7. Maintenance

Warning

1. Do not touch the product, pipes, or the lever [4] with bare hands.
* Failure to follow this notice may result in scalds or injury in case that the fluid is hot.
2. Wear earplugs when checking the operation of the product, and do not stand in front of the discharge pipe. Do not look into the pipe or put your hands out to the pipe.
* The product makes a loud blowing noise during operation. Failure to follow this notice may cause scalds or injury due to blowout.
3. Do not disassemble the product.
* Please contact us if anything abnormal is noticed.

Caution

1. In case of raising the fluid pressure, check beforehand that no problems will occur regarding the equipment installed onto the piping.
* Failure to follow this notice may damage the equipment.
2. Completely discharge the fluid from the product and piping before leaving the product not operated for a long time.
* Failure to follow this notice may cause foreign substances and scale inside of the piping and may result in malfunction of the product.
3. If the product is not operated for a long time, perform test working before starting operation.

7.1 Daily inspection

Please check below during the system is in operation.

- There is no corrosion or crack with the product
- No leakage from the product at the normal working pressure. (No leak sound, etc.)
- No leakage from the mounting connection of the product.

* Please contact us if anything abnormal is noticed.

7.2 Periodic inspection (per month)

- (1) Check to see that the product is securely connected to both inlet and outlet piping without any loose connection.
- (2) Increase the fluid pressure to the set pressure and check that the product operates properly.
- (3) Increase the fluid pressure to 80% of the set pressure or higher, and check that the fluid discharges by operating the lever [4].

* Please contact us if anything abnormal is noticed.

7.3 Troubleshooting

Trouble	Cause	Remedy
Leakage from outlet *	1. Foreign substance is stuck between valve and valve seat.	1. Follow the procedure described in 7.2 (2) to operate the product and eliminate the foreign substances. Please contact us if the leakage does not stop.
	2. Sealing surface of valve seat is damaged.	2. The product needs to be replaced. Please contact us.
	3. Vibration transmitted from the piping, on which the product is installed, causes malfunction of the product.	3. Do not use the product to equipment or device that vibrates excessively.
	4. The pressure momentarily exceeds the set pressure because of fluid pulsation.	4. In view of fluid pulsation, the set pressure needs to be raised (readjusted) or the normal working pressure needs to be lowered. The product needs to be returned to Yoshitake to raise (readjust) the set pressure.
	5. Difference between the set pressure and the normal working pressure is too small.	5. The product needs to be returned to Yoshitake.
	6. Fluid flows into the outlet piping.	6. Change the piping layout to keep the fluid from flowing into the outlet piping.
Blows at a pressure lower than the set pressure	1. Product specifications are not consistent with the usage conditions.	1. Check the set pressure value shown on the nameplate. If the product is not suitable for the usage conditions, replace it with a proper one.
	2. Pressure gauge is out of order.	2. Calibrate or replace the pressure gauge.
	3. Sealing surface of valve seat is damaged.	3. The product needs to be replaced. Please contact us.
	4. The product does not keep the accuracy of its set pressure.	4. The product needs to be returned to Yoshitake for set pressure adjustment.
Does not blow at the set pressure	1. Product specifications are not consistent with the usage conditions.	1. Check the set pressure value shown on the nameplate. If the product is not suitable for the usage conditions, replace it with a proper one.
	2. Pressure gauge is out of order.	2. Calibrate or replace the pressure gauge.
	3. The product does not keep the accuracy of its set pressure.	3. The product needs to be returned to Yoshitake for set pressure adjustment.
	4. Sliding parts of the valve and valve seat do not move smoothly.	4. The product needs to be returned to Yoshitake, and disassembled and cleaned.
	5. There is a back pressure at the piping of the product outlet.	5. Remove the back pressure. Change the piping layout to eliminate the back pressure.

Trouble	Cause	Remedy
Continuous blowout.	1. Foreign substance is stuck between valve and valve seat.	1. The product needs to be returned to Yoshitake, and disassembled and cleaned.
	2. Sliding parts of the valve and valve seat do not move smoothly.	2. The product needs to be returned to Yoshitake, and disassembled and cleaned.
	3. Normal working pressure is higher than closing pressure.	3. The difference between set pressure and normal working pressure needs to be bigger. Please contact us for set pressure adjustment.
	4. The product is installed at outlet side of pressure reducing valve which is out of order, and the reduced pressure of the valve is getting higher than expected.	4. The pressure reducing valve needs repair. If it is Yoshitake's, please contact us.
The lever does not lift up.	1. Inlet pressure is too low.	1. Increase the inlet pressure to 80% of the set pressure or higher.
	2. Sliding part of the spindle does not move smoothly.	2. The product needs to be returned to Yoshitake, and disassembled and cleaned.
Does not stop blowing when releasing the lever after pulling it up.	1. Foreign substance is stuck between valve and valve seat.	1. Remove the foreign substance by operating the product with the lever. Please contact us for repair if the trouble still exists even after that.
	2. Sliding parts of the valve and valve seat do not move smoothly.	2. The product needs to be returned to Yoshitake, and disassembled and cleaned.

* The product has allowable valve seat leakage and does not close completely. (Valve seat leakage cannot be zero.)

Warranty Information

1. Limited warranty

This product has been manufactured using highly-advanced techniques and subjected to strict quality control. Please be sure to use the product in accordance with instructions on the manual and the label attached to it.

Yoshitake warrants the product to be free from any defects in material and workmanship under normal usage for a period of one year from the date of receipt by the original user, but no longer than 24 months from the date of shipment from Yoshitake's factory.

2. Parts supply after product discontinuation

This product may be subject to discontinuation or change for improvement without any prior notice. After the discontinuation of the product, Yoshitake supplies the repair parts for 5 years otherwise individually agreed.

3. This warranty does not cover the damage due to any of below:

- (1) Valve seat leakage or malfunction caused by foreign substances inside piping.
- (2) Improper handling or misuse.
- (3) Improper supply conditions such as abnormal water pressure/quality.
- (4) Water scale or freezing.
- (5) Trouble with power/air supply.
- (6) Any alteration made by other than Yoshitake.
- (7) Use under severe conditions deviating from the design specifications (e.g. in case of corrosion due to outdoor use).
- (8) Fire, flood, earthquake, thunder and other natural disasters.
- (9) Consumable parts such as O-ring, gasket, diaphragm and etc.

Yoshitake is not liable for any damage or loss caused by malfunction or defect of the product.

YOSHITAKE 