



# MODEL GD-26GS, GD-27GS Pressure Reducing Valve

## PRODUCT MANUAL

Thank you very much for choosing the Yoshitake's product. To ensure the correct and safe use of the product, please read this manual before use. This manual shall be kept with care for future reference.  
The symbols used in this manual have the following meanings.

	<b>Warning</b>	This symbol indicates a potentially hazardous situation that, if not avoided, could result in death or serious injury.
	<b>Caution</b>	This symbol indicates a hazardous situation that, if not avoided, may result in minor or moderate injury or may result in only property damage.

---

### Table of Contents

---

2. Specifications	
2.1 Specifications .....	1
2.2 Nominal size selection .....	2 - 3
2.3 Flow rate characteristics chart .....	3
2.4 Pressure characteristics chart .....	4
4. Operation .....	7
5. Maintenance and inspection	
5.1 Precaution for operation .....	7 - 8
5.2 Warning and caution for operation .....	8
5.3 Piping example .....	8
5.4 Adjusting procedure .....	9
5.5 Troubleshooting .....	9
5.6 Warning for disassembly and inspection .....	10
5.7 Disassembly .....	10
6. Exploded view .....	11 - 12

# YOSHITAKE

## 1. Specifications



### Caution

(1) Please collate with attached nameplate and specification of ordered model.  
 ※Please consult factory in case they do not match each other.

### 1.1 Specifications

Model		GD-26GS	GD-27GS
Nominal size		20A - 50A	20A - 100A
Application		Air, Other non-dangerous fluids	
Inlet pressure		1.0 MPa or less	
Reduced pressure	A	0.05 - 0.35 MPa	
	B	0.30 - 0.70 MPa	
Min. differential pressure		0.05 MPa	
Max. pressure reduction ratio		10:1	
Application temperature		5 - 90°C	
Material	Body	Cast stainless steel	
	Valve seat	Cast stainless steel	
	Valve disc	EPDM	
	Diaphragm	EPDM	
Connection		JIS Rc screwed	JIS 10K FF flanged

- The products of the nominal size 20A to 50A incorporate a strainer (40 mesh).
- Pressure gauge connection port is JIS R1/4. The maximum temperature of the pressure gauge is 45°C. If the fluid temperature exceeds 45°C, please protect the pressure gauge by using a siphon tube or similar.



### Caution

(1) For medium including oil, use fluorine rubber for disc and diaphragm.  
 \* If not, disc and diaphragm may be broken.

## 1.2 Nominal size selection

<For Air>

● Nominal size selection chart

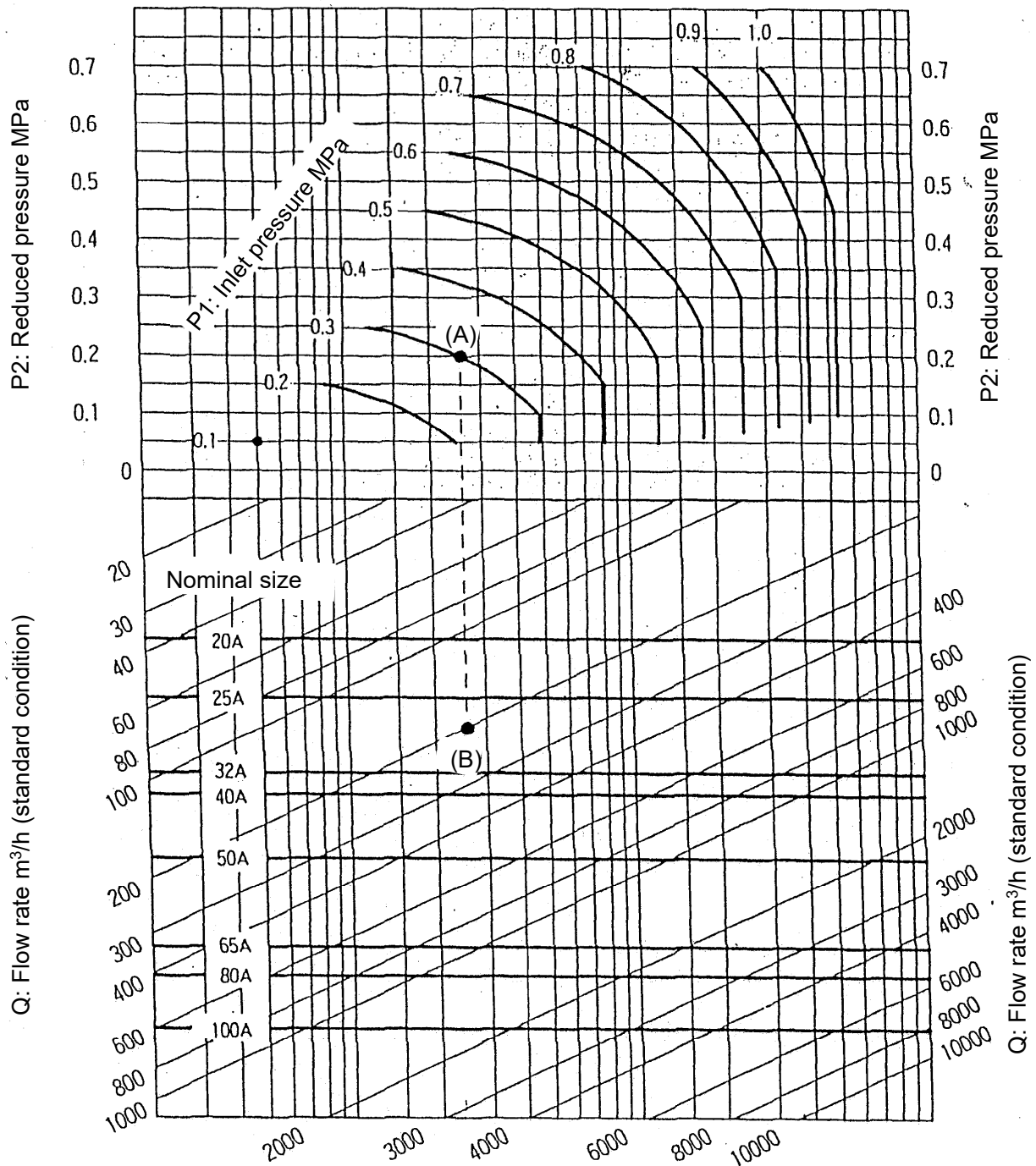

### [Example]

When selecting the nominal size of a pressure reducing valve whose inlet pressure (P1), reduced pressure (P2), and flow rate are 0.3 MPa, 0.2 MPa, and 200 m<sup>3</sup>/h (standard condition), respectively, first find intersection point (A) of the inlet pressure (P1) of 0.3 MPa and the reduced pressure (P2) of 0.2 MPa.

Trace down vertically from the intersection point to find intersection point (B) with the flow rate of 200 m<sup>3</sup>/h (standard condition). Since intersection point (B) lies between nominal size 25A and 32A, select the larger one, 32A.

● Nominal size selection calculation formula

- Cv value calculation formula

$$P_2 > \frac{P_1}{2}$$

$$C_v = \frac{Q}{2940} \sqrt{\frac{(273 + t)G}{\Delta P(P_1 + P_2)}}$$

$$P_2 \leq \frac{P_1}{2}$$

$$C_v = \frac{Q\sqrt{(273 + t)G}}{2550P_1}$$

Q: Max. Fluid flow rate [m<sup>3</sup>/h (standard condition)]

P<sub>1</sub>: Inlet pressure [MPa · A]

P<sub>2</sub>: Reduced pressure [MPa · A]

ΔP: P<sub>1</sub> - P<sub>2</sub> [MPa]

G: Specific gravity

(Specific gravity per air)

t: Fluid temperature [°C]

Nominal size	20A	25A	32A	40A	50A	65A	80A	100A
Rated Cv value	2.3	3.5	6	7	11	21	26	38

1.3 Flow rate characteristics chart

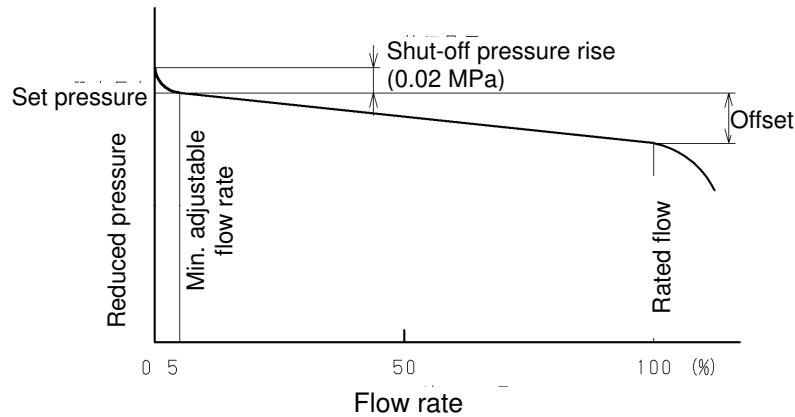

Offset

Pressure range	Reduced pressure range	Offset
A	0.05 - 0.35 MPa	0.05 MPa or less
B	0.30 - 0.70 MPa	0.10 MPa or less

## 1.4 Pressure characteristics chart

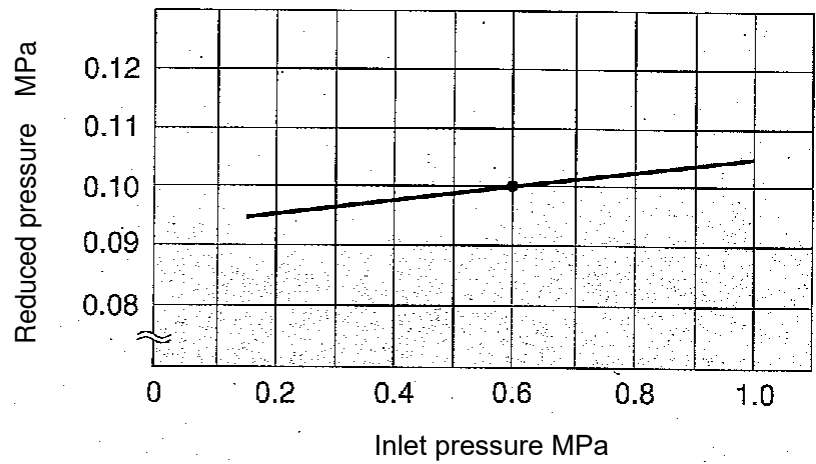

This chart shows variation in the reduced pressure when the inlet pressure of 0.60 MPa is changed between 0.15 MPa and 1.0 MPa after the reduced pressure is set at 0.10 MPa.

## 2. Operation

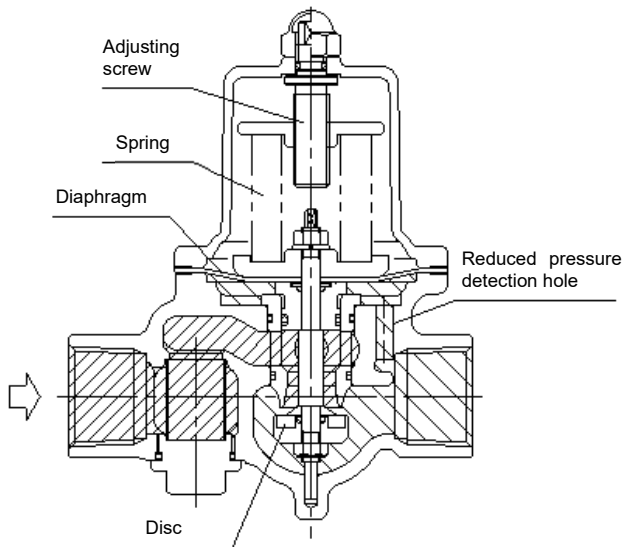

The spring is compressed by the adjusting screw, the diaphragm is pushed down, and thereby the disc directly connected to it is opened. Fluid coming in from the inlet side flows out from the upper part of the disc to the outlet side, and passes through the reduced pressure detection hole, and is led to the bottom of the diaphragm. The load of the spring and the reduced pressure act to the diaphragm, and the upper and lower force keeps a balance and regulates the valve opening. As a result, the diaphragm keeps the reduced pressure constant.

### 3. Maintenance and inspection

#### 3.1 Precaution for operation

**⚠ Caution**

1. Do not disassemble the product unless it is necessary.  
\* Unnecessary disassembly prevents the product from functioning properly.
2. Before installing the product in the piping, be sure to remove foreign substances and scale from the piping.  
\* Ingress of foreign substances, scale or seal agent into the product leads to valve leakage or malfunction of the product.
3. Be sure to install a strainer at the inlet side of the product of nominal size 65A to 100A.  
\* Ingress of foreign substances or scale into the product leads to malfunction of the product. It is recommended to use a strainer of 40 mesh or more.
4. Install a safety relief valve for equipment protection at the outlet side of the product.  
\* Failure to follow this notice may result in damage of the equipment.
5. Be sure to install pressure gauges at the inlet and outlet sides of the product.  
\* Failure to follow this notice hampers correct pressure adjustment.
6. If a quick operating valve such as a solenoid valve is installed, place it at a distance of at least 3 meters from the product.  
\* Failure to follow this notice may result in malfunction or a drastically shortened service life of the product.
7. For two-stage pressure reduction, keep a distance of at least 3 meters between each product.  
\* Failure to follow this notice may prevent the product from functioning properly due to malfunction.
8. Install the product properly by checking the inlet, outlet and proper posture.  
\* Installing the product in wrong directions prevents the product from functioning properly.
9. Install pipes so that excessive load, torque or vibration is not applied to the product.  
\* Failure to make durability lower or cause malfunction.

- (1) The product can be installed either horizontally or vertically.
- (2) When using a product with a pressure gauge outdoors, provide a canopy or other protection to prevent rainwater from directly hitting the pressure gauge.
- (3) A space more than the value shown as H<sub>2</sub> in the table below is required for disassembly and inspection.  
A space more than the value shown as H<sub>3</sub> in the table below is required for the inspection of the built-in strainer (nominal size 15A to 50A).

Nominal size	20A	25A	32A	40A	50A	65A	80A	100A
H <sub>2</sub>	250	250	300	300	320	450	450	550
H <sub>3</sub>	90	90	120	120	150	-	-	-

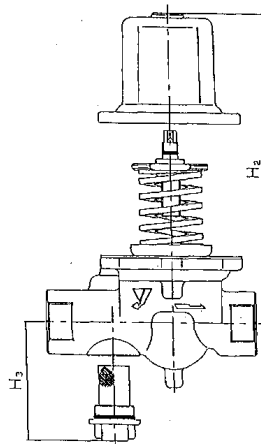

### 3.2 Warning and caution for operation



#### Warning

When the product is used for hot fluid, do not touch the product with bare hands.  
\* The product having hot fluid may scald your skin.



#### Caution

1. Before leading fluid into the product, close the stop valves at the inlet and outlet of the product and remove foreign substances and scale from the piping completely by using a bypass line.  
\* Failure to follow this notice may prevent the product from functioning properly due to the ingress of foreign substances and scale into the product.
2. To adjust the set pressure, turn the adjusting screw slowly.  
\* Failure to follow this notice may result in damage to the product and other equipment due to hunting or other cause.
3. When the product is not used for an extended period, completely discharge fluid from the product and pipes, and close the stop valves at the inlet and outlet sides of the product.  
\* Failure to follow this notice causes malfunction of the product due to rusting inside the product and the pipes.
4. The set pressure may be affected by ambient temperature (external temperature) and fluid temperature. Install pipes so that the product may not be exposed to direct sunlight.

### 3.3 Piping example

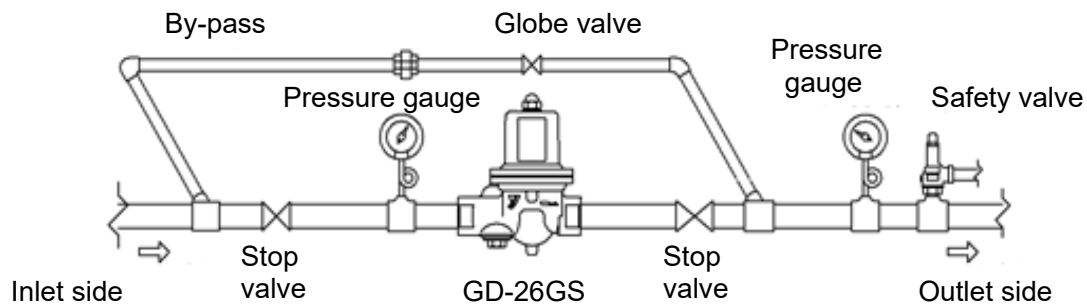

### 3.4 Adjusting procedure

Following a wrong adjusting procedure may cause hunting, scale problems or other problem, and can heavily damage the main parts of the valve. To avoid these problems, be sure to follow the procedure given below

1. Close the stop valves at the inlet and outlet sides of the reducing valve, and take adequate time to blow out fluid by using a bypass line. In doing this, adjust the opening of the globe valve in the bypass pipe so as not to blow out the safety relief valve. After the end of blowing, close the globe valve without fail.
2. Fully open the stop valve at the inlet side slowly, and open the stop valve at the outlet side so that a little fluid can flow through.
3. Remove the domed cap nut and turn the adjusting screw [14] while watching the pressure gauge at the outlet side.
  - Turn the adjusting screw to the right (clockwise) to increase the reduced pressure.
  - Turn the adjusting screw to the left (counterclockwise) to decrease the reduced pressure.
4. Fully open the stop valve at the outlet side slowly.
5. After the adjustment is complete, tighten the domed cap nut.

### 3.5 Troubleshooting

Trouble	Cause	Remedy
Abnormal pressure rises at the outlet side.	<ol style="list-style-type: none"> <li>1. Foreign substances stuck between the disc [8] and the valve seat [3], or scratch on them.</li> <li>2. The O-ring [6] is damaged.</li> <li>3. The diaphragm [9] is damaged.</li> <li>4. There is a leakage from the globe valve of the by-pass line.</li> </ol>	<ol style="list-style-type: none"> <li>1. Disassemble the product and remove the foreign substances. If scratch is observed on the valve disc or valve seat, replace it.</li> <li>2. Replace the O-ring.</li> <li>3. Replace the diaphragm.</li> <li>4. Repair or replace the globe valve.</li> </ol>
Reduced pressure does not reach the desired value.	<ol style="list-style-type: none"> <li>1. The working pressure is improper.</li> <li>2. The nominal size of the product is too small for the flow rate for use.</li> <li>3. Pressure adjustment is improper.</li> <li>4. Strainer built in the product is clogged.</li> <li>5. Pressure gauge is broken.</li> </ol>	<ol style="list-style-type: none"> <li>1. Correct the working pressure. (See "2.1 Specifications" on Page 1.)</li> <li>2. Replace the product with the proper nominal size.</li> <li>3. Readjust the pressure in accordance with the given procedure.</li> <li>4. Clean the strainer.</li> <li>5. Replace pressure gauge.</li> </ol>
Abnormal sound	<ol style="list-style-type: none"> <li>1. The nominal size of the product is too large for the specifications of the system.</li> <li>2. The pressure reduction ratio is too large or the maximum pressure difference is exceeded.</li> <li>3. A quick operating valve is located near the product.</li> </ol>	<ol style="list-style-type: none"> <li>1. Replace the product with the proper nominal size. (See "2.2 Nominal size selection" on Page 2.)</li> <li>2. Reduce pressure in two stages. (See "2.1 Specifications" on Page 1)</li> <li>3. Keep a distance between them as large as possible.</li> </ol>

- Most of problems with the pressure reducing valve are caused by foreign substances and scale in the piping. Avoid the ingress of dust and dirt to the product with caution.
- A phenomenon similar to valve failure could occur due to the failure of the pressure gauge, leakage or insufficient tightening of the globe valve in the by-pass line, clogging of the strainer, and other causes. Check the above possible causes and take a proper remedy and preventive measures.



### 3.6 Warning for disassembly and inspection

#### **Warning**

1. Completely discharge the pressure inside of the product, piping and equipment before disassembly and inspection. Disassembly and inspection must be done by experienced professional or valve manufacturer.  
\* Failure to follow this notice may result in scalds, injury or contamination on the surroundings due to the residual pressure.

### 3.7 Disassembly

1. Exhaust pressure in the piping completely and check if pressure is 0MPa by pressure gauge.
2. Remove the domed cap nut, turn the adjusting screw [14] counterclockwise, and set the spring [15] free (no load).
3. Remove the bolts of the spring chamber [2] and remove the spring chamber [2]. Then take out the spring [15] and the spring plate [13].
4. Remove the nut, and then the diaphragm shell [12], and diaphragm [9].
5. Remove the set screws of the valve seat [3], and remove a set of the valve seat.

Nominal size 15A to 50A: Attach the diaphragm shell [12] to the spindle [4], and pull it up.

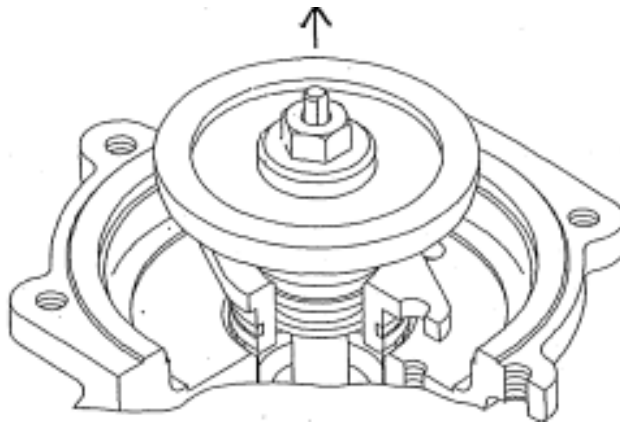

Nominal size 65A to 100A: Screw the bolt into the valve seat [3], and pull it up.

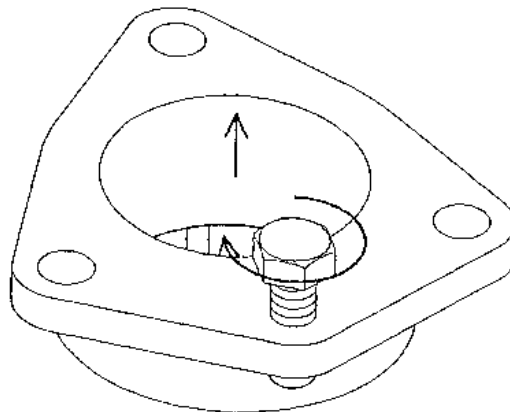

## 4. Exploded view

Nominal size 20A - 50A

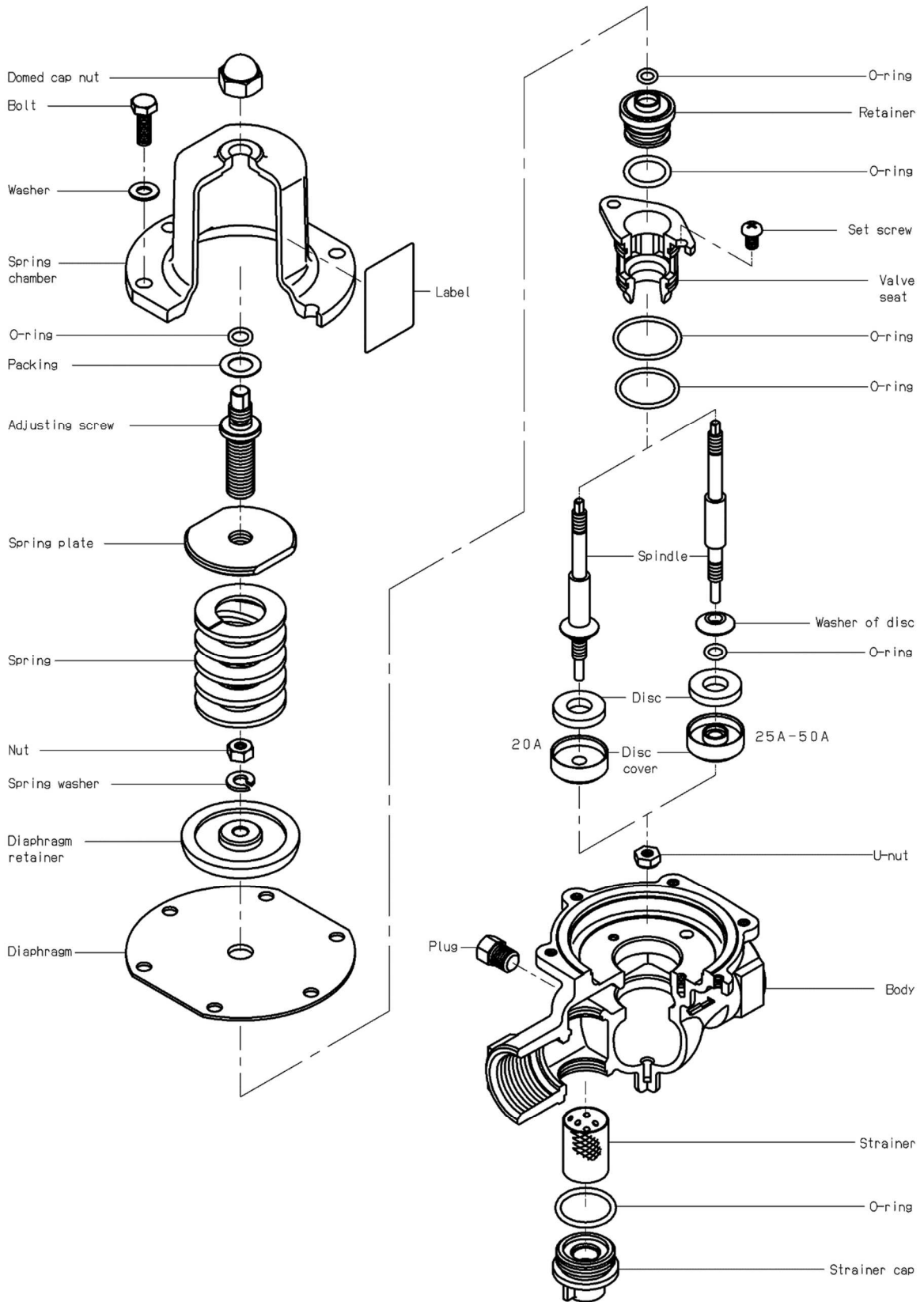

Nominal size 65A-100A

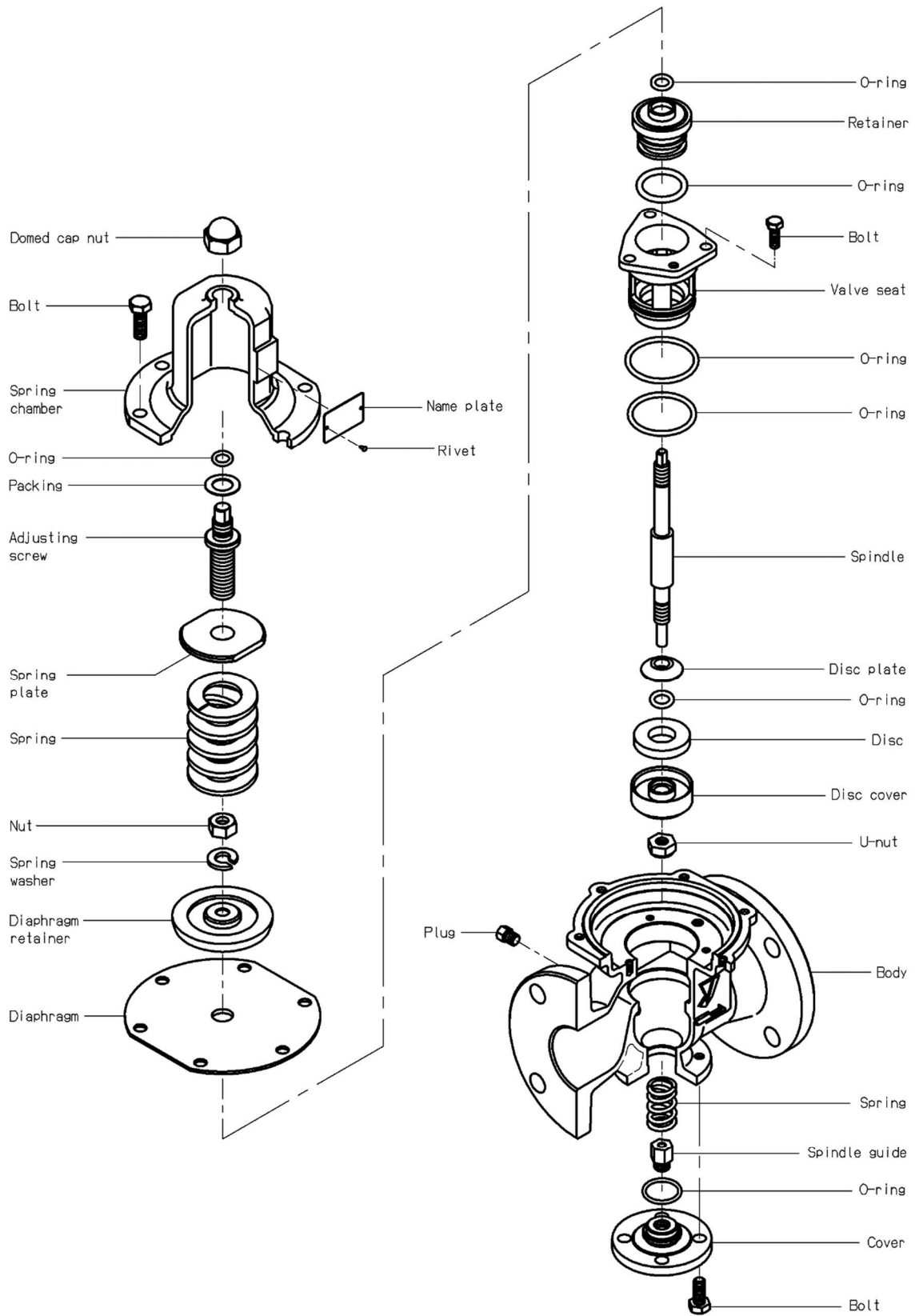

---

## Warranty Information

---

1. Limited warranty

This product has been manufactured using highly-advanced techniques and subjected to strict quality control. Please be sure to use the product in accordance with instructions on the manual and the label attached to it.

Yoshitake warrants the product to be free from any defects in material and workmanship under normal usage for a period of one year from the date of receipt by the original user, but no longer than 24 months from the date of shipment from Yoshitake's factory.

2. Parts supply after product discontinuation

This product may be subject to discontinuation or change for improvement without any prior notice. After the discontinuation of the product, Yoshitake supplies the repair parts for 5 years otherwise individually agreed.

3. This warranty does not cover the damage due to any of below:

- (1) Valve seat leakage or malfunction caused by foreign substances inside piping.
- (2) Improper handling or misuse.
- (3) Improper supply conditions such as abnormal water pressure/quality.
- (4) Water scale or freezing.
- (5) Trouble with power/air supply.
- (6) Any alteration made by other than Yoshitake.
- (7) Use under severe conditions deviating from the design specifications (e.g. in case of corrosion due to outdoor use).
- (8) Fire, flood, earthquake, thunder and other natural disasters.
- (9) Consumable parts such as O-ring, gasket, diaphragm and etc.

Yoshitake is not liable for any damage or loss caused by malfunction or defect of the product.