

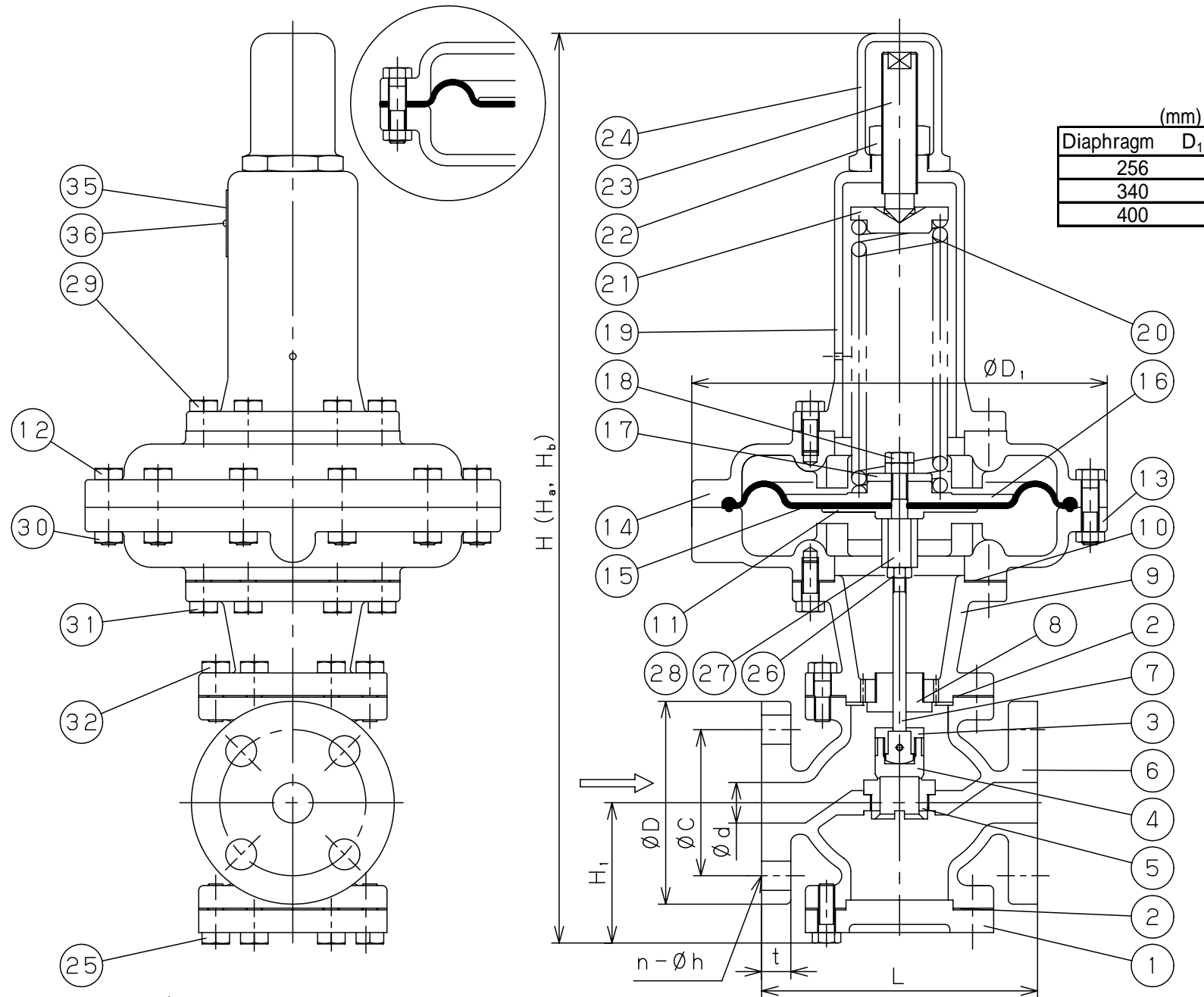

※ $\phi D_1 = \phi 340, \phi 400$



36	Rivet	Carbon Steel	打込みねじ	S15C	2
35	Name Plate	Stainless Steel	銘板	SUS304	1
32	Bolt	Rolled Steel	六角ボルト	SS400	1set
31	Bolt	Rolled Steel	六角ボルト	SS400	1set
30	Nut	Rolled Steel	ナット	SS400	1set
29	Bolt	Rolled Steel	六角ボルト	SS400	1set
28	O-Ring	NBR	Oリング	NBR	1
27	Stem Joint	Brass	弁棒接手	C3604	1
26	Lock Nut	Brass	ロックナット	C3604	1
25	Bolt	Rolled Steel	六角ボルト	SS400	1set
24	Cap	Cast Iron	キャップ	FC200	1
23	Adjusting Screw	Brass	調節ねじ	C3604	1
22	Lock Nut	Rolled Steel	ロックナット	SS400	1
21	Spring Plate	Cast Iron	ばね受	FC200	1
20	Spring	Alloy Steel or ITW	調節ばね	SWOSM or SWI	1
19	Spring Chamber	Cast Iron	保護筒	FC200	1
18	Lock Nut	Brass	ロックナット	C3604	2
17	Plain Washer	Rolled Steel	平座金	SS400	0or1
16	Washer of Diaphragm	Cast Iron or Carbon Steel	ダイヤフラム受け	FC200 or SPC	1
15	Diaphragm	NBR	ダイヤフラム	NBR	1
14	Diaphragm Cover	Cast Iron	ダイヤフラムカバー	FC200	1
13	Diaphragm Cover	Cast Iron	ダイヤフラムカバー	FC200	1
12	Stud Bolt	Rolled Steel	スタットボルト	SS400	1set
11	Washer of Diaphragm	Rolled Steel	ダイヤフラム受け	SS400	1
10	Gasket	Non-Asbestos	ガスケット	Non-Asbestos	1
9	Top Cover	Cast Iron	上部カバー	FC200	1
8	Spindle Guide	Brass	弁棒ガイド	C3604	1
7	Spindle	Stainless Steel	弁棒	SUS304	1
6	Body	Cast Iron	本体	FC200	1
5	Valve Seat	Stainless Steel	弁座	SUS403	1
4	Valve	Stainless Steel	弁体	SUS304	1
3	Glande	Stainless Steel	弁体押え	SUS304	1
2	Gasket	Non-Asbestos	ガスケット	Non-Asbestos	2
1	Bottom Cover	Cast Iron	下部カバー	FC200	1
	Name of Parts	Material	部品名	材質	Q.TY

1 H寸法は、ダイヤフラム径により異なります。

The 'H' dimension differs according to the diaphragm diameter.

Ha : Diaphragm 256

Hb : Diaphragm 340、400

2 製品質量は、ダイヤフラム径256mmのものであり、340mmの時は5kg、400mmの時は9kgを加算して下さい。

Indicated weights are for valves with 256mm diaphragms. For a 340mm diaphragm, add 5kg, and for a 400mm diaphragm, add 9kg.

Size	L	H_1	1 H		Flange JIS 10KFF					Weight 2(kg)
			Ha	Hb	d	D	C	t	n-h	
20A	170	90	565	580	20	100	75	18	4-15	27
25A	170	90	565	580	25	125	90	18	4-19	28
32A	180	100	585	600	32	135	100	20	4-19	28
40A	180	100	585	600	40	140	105	20	4-19	29
50A	180	105	595	610	50	155	120	20	4-19	31

Specification	
Fluid	
Primary Press.	kPa
Back Press.	kPa
Temp.	
Flow Rate	

PRIMARY PRESSURE
REGULATING VALVE
TYPE GD-4R
一次圧力調整弁

Approval	M. Kume
Check	Y. Aoyama
Drawing	M. Yoshida
Drawing No.	Y-011-0805
Date	29 JUN. 2009

Yoshitake
INC.
<http://www.yoshitake.co.jp>

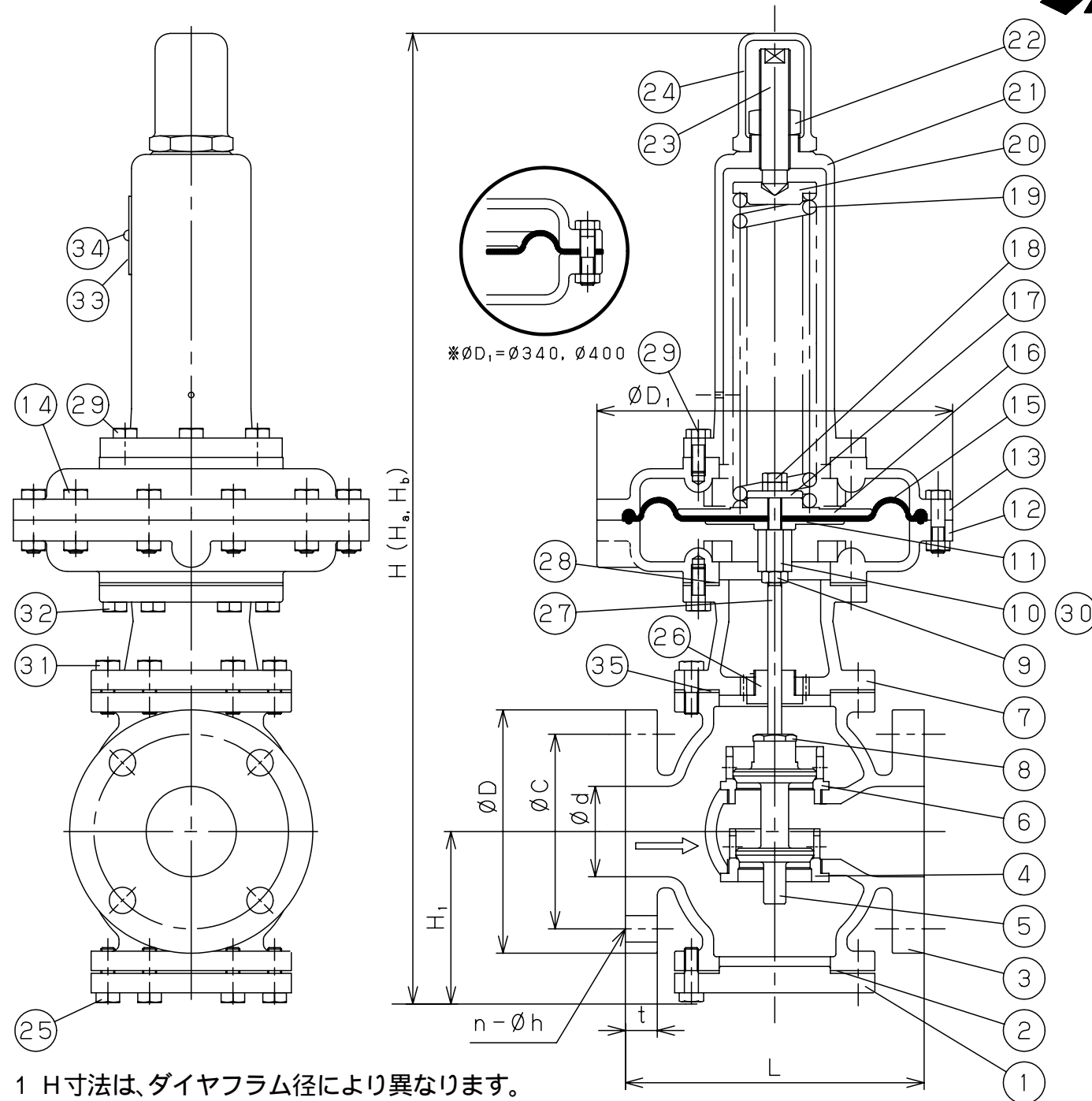

(mm)	
Diaphragm	D ₁
	256
	340
	400

35	Gasket	Non-Asbestos	ガスケット	Non-Asbestos	1
34	Rivet	Carbon Steel	打込みねじ	S15C	2
33	Name Plate	Stainless Steel	銘板	SUS304	1
32	Bolt	Rolled Steel	六角ボルト	SS400	1set
31	Bolt	Rolled Steel	六角ボルト	SS400	1set
30	O-Ring	NBR	Oリング	NBR	1
29	Bolt	Rolled Steel	六角ボルト	SS400	1set
28	Gasket	Non-Asbestos	ガスケット	Non-Asbestos	1
27	Spindle	Stainless Steel	弁棒	SUS304	1
26	Spindle Guide	Brass	弁棒ガイド	C3604	1
25	Bolt	Rolled Steel	六角ボルト	SS400	1set
24	Cap	Cast Iron	キャップ	FC200	1
23	Adjusting Screw	Brass	調節ねじ	C3604	1
22	Lock Nut	Rolled Steel	ロックナット	SS400	1
21	Spring Chamber	Cast Iron	保護筒	FC200	1
20	Spring Plate	Cast Iron	ばね受	FC200	1
19	Spring	Alloy Steel or ITW	調節ばね	SWOSM or SWI	1
18	Lock Nut	Brass	ロックナット	C3604	2
17	Plain Washer	Rolled Steel	平座金	SS400	0or1
16	Washer of Diaphragm	Cast Iron or Carbon Steel	ダイヤフラム受け	FC200 or SPC	1
15	Diaphragm	NBR	ダイヤフラム	NBR	1
14	Bolt & Nut	Rolled Steel	六角ボルト&ナット	SS400	1set
13	Diaphragm Cover	Cast Iron	ダイヤフラムカバー	FC200	1
12	Diaphragm Cover	Cast Iron	ダイヤフラムカバー	FC200	1
11	Washer of Diaphragm	Rolled Steel	ダイヤフラム受け	SS400	1
10	Stem Joint	Brass	弁棒接手	C3604	1
9	Lock Nut	Brass	ロックナット	C3604	1
8	Glände	Stainless Steel	弁体押え	SUS304	1
7	Top Cover	Cast Iron	上部カバー	FC200	1
6	Valve Seat	Stainless Steel	弁座	SUS403	1
5	Valve	Stainless Steel	弁体	SUS304	1
4	Valve Seat	Stainless Steel	弁座	SUS403	1
3	Body	Cast Iron	本体	FC200	1
2	Gasket	Non-Asbestos	ガスケット	Non-Asbestos	1
1	Bottom Cover	Cast Iron	下部カバー	FC200	1
	Name of Parts	Material	部品名	材質	Q.TY

- 1 H寸法は、ダイヤフラム径により異なります。
The 'H' dimension differs according to the diaphragm diameter.
Ha : Diaphragm 256
Hb : Diaphragm 340、400
- 2 製品質量は、ダイヤフラム径256mmのものであり、340mmの時は5kg、400mmの時は9kgを加算して下さい。
Indicated weights are for valves with 256mm diaphragms. For a 340mm diaphragm, add 5kg, and for a 400mm diaphragm, add 9kg.

Size	L	H ₁	1 H		Flange JIS 10KFF					Weight 2(kg)
			Ha	Hb	d	D	C	t	n-h	
65A	215	125	700	715	65	175	140	22	4-19	39
80A	260	135	715	730	80	185	150	22	8-19	48
100A	300	160	785	800	100	210	175	24	8-19	64
125A	360	190	840	855	125	250	210	24	8-23	88
150A	382	220	895	910	150	280	240	26	8-23	123

Specification	
Fluid	
Primary Press.	kPa
Back Press.	kPa
Temp.	
Flow Rate	

PRIMARY PRESSURE REGULATING VALVE
TYPE GD-4R
一次圧力調整弁

Approval	M. Kume
Check	Y. Aoyama
Drawing	M. Yoshida
Drawing No.	Y-011-0805
Date	30 JUN. 2009

