

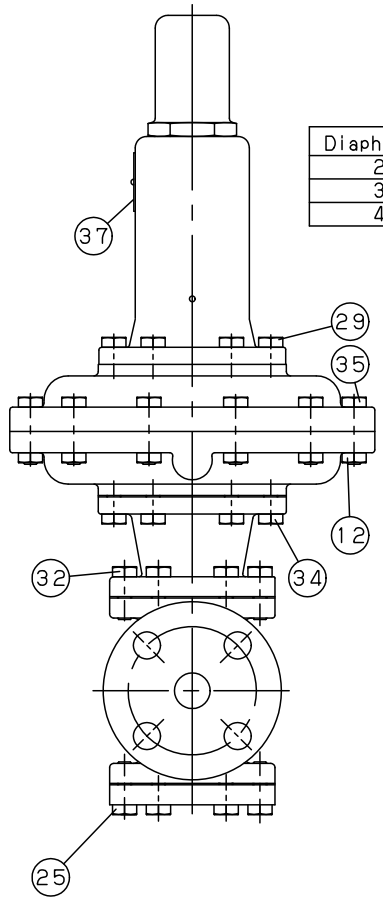

※1 H寸法は、ダイヤフラム径によって異なります。  
 The "H" dimension differs according to the diaphragm diameter.  
 Ha: Diaphragm Ø256mm  
 Hb: Diaphragm Ø340mm, Ø400mm

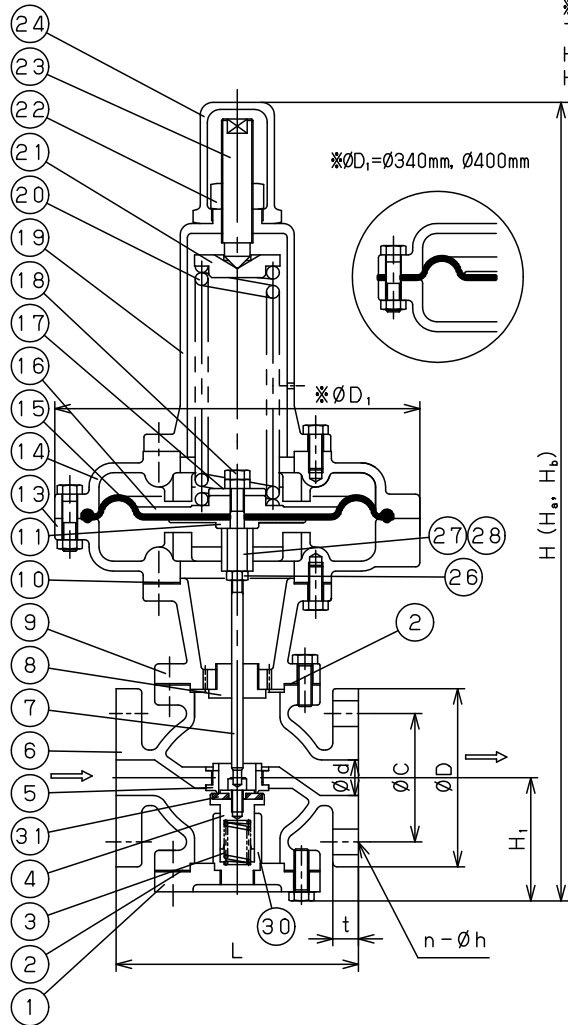

37	Name Plate	Stainless Steel	銘板	SUS304	1
35	Bolt	Steel	ボルト	Steel	12
34	Bolt	Steel	ボルト	Steel	6
32	Bolt	Steel	ボルト	Steel	6
31	Disc	NBR	ディスク	NBR	1
30	Valve Guide	Brass	弁ガイド	C3604	1
29	Bolt	Steel	六角ボルト	Steel	6
28	O Ring	NBR	Oリング	NBR	1
27	Stem Joint	Brass	弁棒接手	C3604	1
26	Lock Nut	Brass	ロックナット	C3604	1
25	Bolt	Steel	ボルト	Steel	6
24	Cap	Cast Iron	キャップ	FC200	1
23	Adjusting Screw	Brass	調節ねじ	C3604	1
22	Lock Nuts	Steel	ロックナット	Steel	1
21	Spring Plate	Cast Iron	ばね受	FC200	1
20	Spring	Alloy Steel or ITW	調節ばね	SWOSM or SWI	1
19	Spring Chamber	Cast Iron	保護筒	FC200	1
18	Lock Nuts	Stainless Steel	ロックナット	SUS	2
17	Plain Washer	Steel	平座金	Steel	0or1
16	Washer of Diaphragm	Cast Iron or Carbon Steel	ダイヤフラム受	FC200 or SPC	1
15	Diaphragm	NBR	ダイヤフラム	NBR	1
14	Diaphragm Cover	Cast Iron	ダイヤフラムカバー	FC200	1
13	Diaphragm Cover	Cast Iron	ダイヤフラムカバー	FC200	1
12	Nut	Steel	ナット	Steel	12
11	Washer of Diaphragm	Rolled Steel	ダイヤフラム受	SS400	1
10	Gasket	Non-Asbestos	ガスケット	Non-Asbestos	1
9	Top Cover	Cast Iron	上部カバー	FC200	1
8	Spindle Guide	Brass	弁棒ガイド	C3604	1
7	Spindle	Stainless Steel	弁棒	SUS304	1
6	Body	Cast Iron	本体	FC200	1
5	Valve Seat	Stainless Steel	弁座	SUS403	1
4	Valve	Brass	弁	C3604	1
3	Spring	Stainless Steel	ばね	SUS304	1
2	Gasket	Non-Asbestos	ガスケット	Non-Asbestos	2
1	Bottom Cover	Cast Iron	下部カバー	FC200	1
№	Name of Parts	Material	部品名	材質	Q. TY

Size	L	H <sub>1</sub>	※1 H		d	Flange JIS 10K FF			
			H <sub>a</sub>	H <sub>b</sub>		D	C	t	n-h
15A	166	90	565	580	15	95	70	16	4-15
20A	170	90	565	580	20	100	75	18	4-15
25A	170	90	565	580	25	125	90	18	4-19
32A	180	100	585	600	32	135	100	20	4-19
40A	180	100	585	600	40	140	105	20	4-19
50A	180	105	595	610	50	155	120	20	4-19

Specification	
Fluid	
Inlet Press.	kPa
Reduced Press.	kPa
Temp.	℃
Flow Rate	

TYPE GD-4 PRESSURE REDUCING VALVE  
減圧弁

Approval	T. Shinjo
Check	T. Shinjo
Drawing	J. Takagi
Drawing No.	Y-010-0705-3B
Date	26 MAR. 2018

**Yoshitake**  
INC.

<http://www.yoshitake.co.jp>

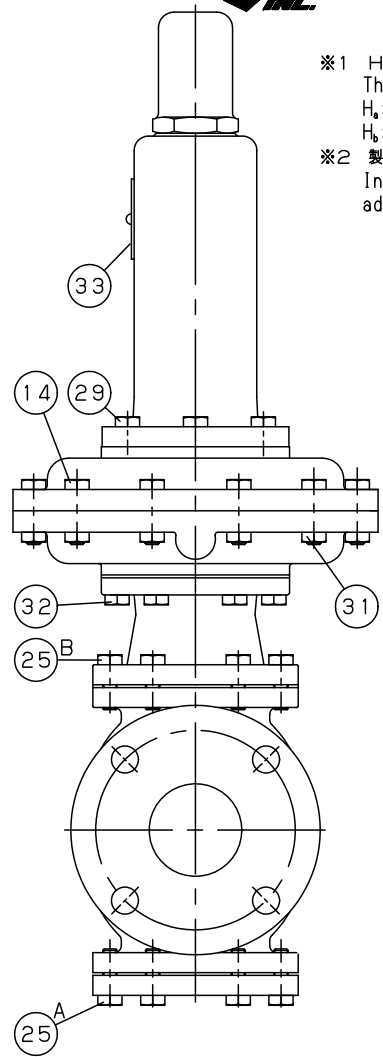
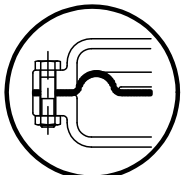
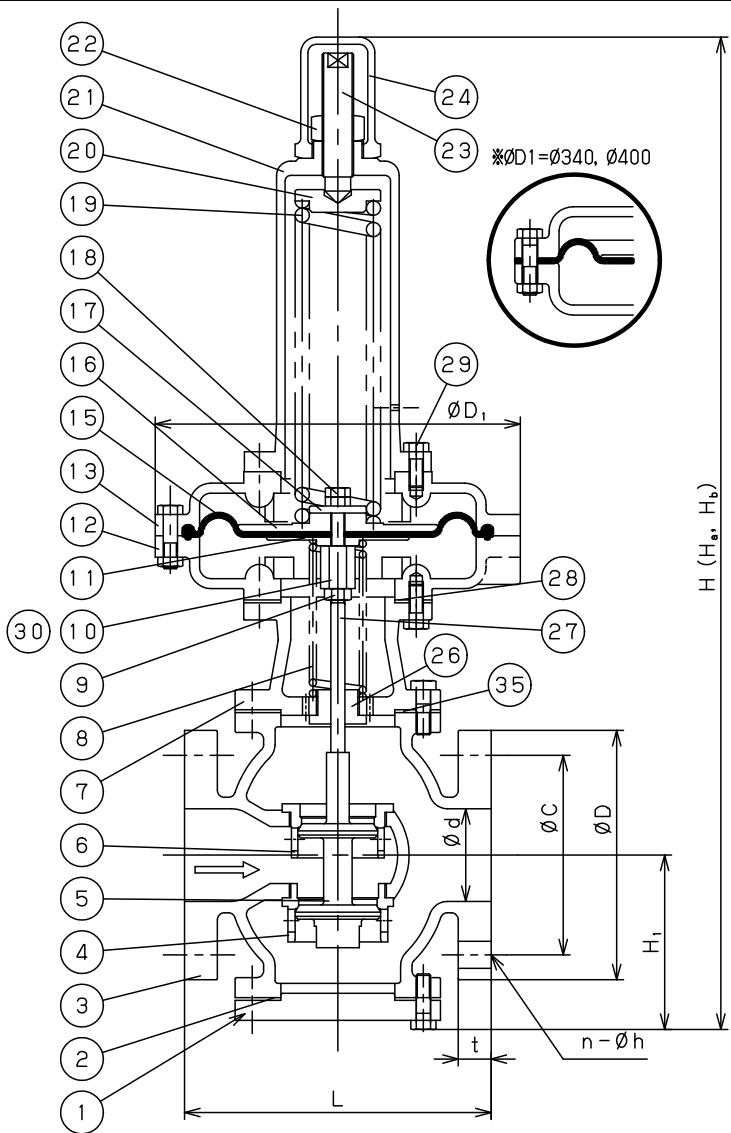

※1 H寸法は、ダイヤフラム径により異なります。  
 The 'H' dimension differs according to the diaphragm diameter.  
 $H_a$ : Diaphragm  $\varnothing 256$   
 $H_b$ : Diaphragm  $\varnothing 340, \varnothing 400$

※2 製品質量は、ダイヤフラム径256mmのものであり、340mmの時は5kg、400mmの時は9kgを加算して下さい。  
 Indicated weights are for valves with 256mm diaphragms. For a 340mm diaphragm, add 5kg, and for a 400mm diaphragm, add 9kg.

No.	Name of Parts	Material	部品名	材質	Q. TY
35	Gasket	Non-Asbestos	ガスケット	Non-Asbestos	1
33	Name Plate	Stainless Steel	銘板	SUS304	1
32	Bolt	Steel	ボルト	Steel	1set
31	Nut	Steel	ナット	Steel	1set
30	O Ring	NBR	オリング	NBR	1
29	Bolt	Steel	ボルト	Steel	1set
28	Gasket	Non-Asbestos	ガスケット	Non-Asbestos	1
27	Spindle	Stainless Steel	弁軸	SUS304	1
26	Spindle Guide	Brass	弁軸ガイド	C3604	1
25	Bolt	Steel	ボルト	Steel	1set
24	Cap	Cast Iron	キャップ	FC200	1
23	Adjusting Screw	Brass	調整ねじ	C3604	1
22	Lock Nut	Steel	ロックナット	Steel	1
21	Spring Chamber	Cast Iron	保護筒	FC200	1
20	Spring Plate	Cast Iron	ばね受	FC200	1
19	Spring	Alloy Steel or ITW	調節ばね	SWOSM or SWI	1
18	Lock Nut	Brass	ロックナット	C3604	2
17	Plain Washer	Steel	平座金	Steel	0or1
16	Washer of Diaphragm	Cast Iron or Carbon Steel	ダイヤフラム受	FC200 or SPC	1
15	Diaphragm	NBR	ダイヤフラム	NBR	1
14	Bolt	Steel	ボルト	Steel	1set
13	Diaphragm Cover	Cast Iron	ダイヤフラムカバー	FC200	1
12	Diaphragm Cover	Cast Iron	ダイヤフラムカバー	FC200	1
11	Washer of Diaphragm	Rolled Steel	ダイヤフラム受	SS400	1
10	Stem Joint	Brass	弁軸継手	C3604	1
9	Lock Nut	Brass	ロックナット	C3604	1
8	Spring	Stainless Steel	ばね	SUS304	1
7	Top Cover	Cast Iron	上部カバー	FC200	1
6	Valve Seat	Stainless Steel	弁座	SUS403	1
5	Valve	Stainless Steel	弁体	SUS304	1
4	Valve Seat	Stainless Steel	弁座	SUS403	1
3	Body	Cast Iron	本体	FC200	1
2	Gasket	Non-Asbestos	ガスケット	Non-Asbestos	1
1	Bottom Cover	Cast Iron	下部カバー	FC200	1

Size	L	$H_1$	※1 H		Flange JIS 10K FF				Weight ※2 (kg)	
			$H_a$	$H_b$	d	D	C	t		
65A	215	125	700	715	65	175	140	22	4-19	39
80A	260	135	715	730	80	185	150	22	8-19	48
100A	300	160	785	800	100	210	175	24	8-19	64
125A	360	190	840	855	125	250	210	24	8-23	88
150A	382	220	895	910	150	280	240	26	8-23	123

Specification	
Fluid	
Inlet Press.	kPa
Reduced Press.	kPa
Temp.	℃
Flow Rate	

(mm)	
Diaphragm $\varnothing D1$	
256	
340	
400	

TYPE GD-4 PRESSURE REDUCING VALVE  
 減圧弁

Approval	T. Shinjo
Check	T. Shinjo
Drawing	J. Takagi
Drawing No.	Y-010-0805-1A
Date	26 MAR. 2018

