

TSF-10CF



■Features

1. The TSF-10CF can discharge condensate effectively without retention, and realize energy saving steam system without steam loss.

It is suitable for steam equipments used in various industries such as air-conditioning equipment, hot-water supply equipment, plant, and food.

2. Incorporated thermostatic air vent discharges air inside the piping and shortens warming-up time.

3. By turning the cock, it is possible to meet various flow direction such as horizontal or vertical installation.

Flow direction can be switched easily without disassembly such as detaching the cover.

4. Since the main parts are installed on the cover, it is possible to disassemble the cover with the body installed on the piping so the inspection and parts replacement can be conducted easily.

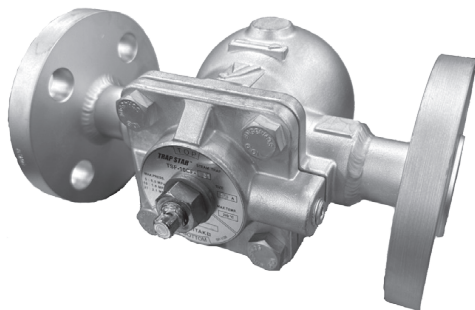

■Specifications

Model		TSF-10CF
Nominal size		15A, 20A, 25A
Application		Steam condensate
Working pressure (Maximum working differential pressure)		TSF-10CF-5: 0.01-0.5 MPa (0.5 MPa) TSF-10CF-10: 0.01-1.0 MPa (1.0 MPa) TSF-10CF-21: 0.01-2.1 MPa (2.1 MPa)
Max. temperature		220°C
Material	Body	Cast carbon steel
	Float	Stainless steel
	Valve, valve seat	Stainless steel
Connection		ASME 150LB RF, ASME 300LB RF, EN PN 25/40 flanged

■Caution for Installation

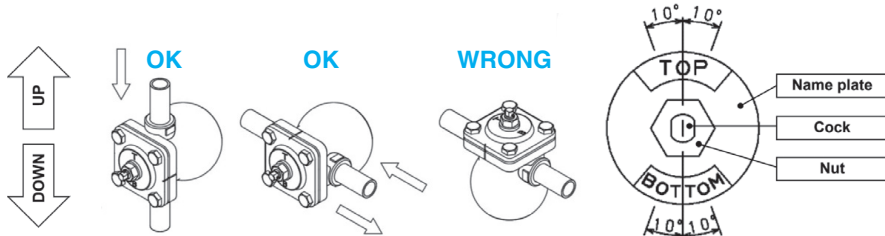

Adjust direction of the name plate in no pressure condition after installation.

Fix the cock with spanner and loosen the nut. Turn the cock and adjust direction of the name plate to position "TOP" and "BOTTOM" signs on upside and downside respectively. Fix the cock with spanner and fasten the nut after adjustment.

■Dimensions (mm) and Weights (kg)

Nominal size	L	A	A ₁	H	Weight(kg)		
					ASME150LB	ASME300LB	EN PN25/40
15A	195	173	88.5	110	4.8	5.0	5.0
20A	215	173	88.5	110	5.2	5.4	5.4
25A	235	173	88.5	110	6.2	6.6	6.6

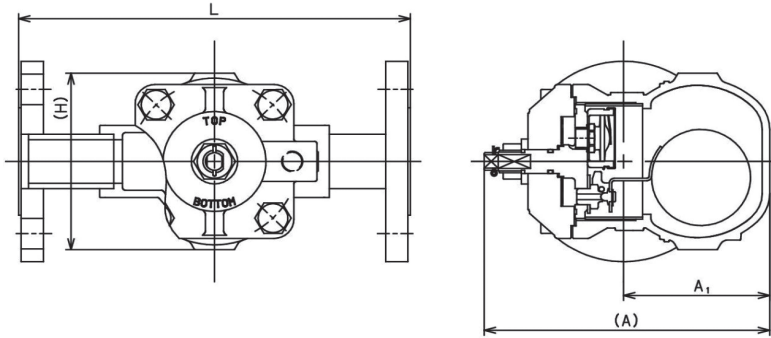

■Maximum Continuous Discharge Capacity Chart

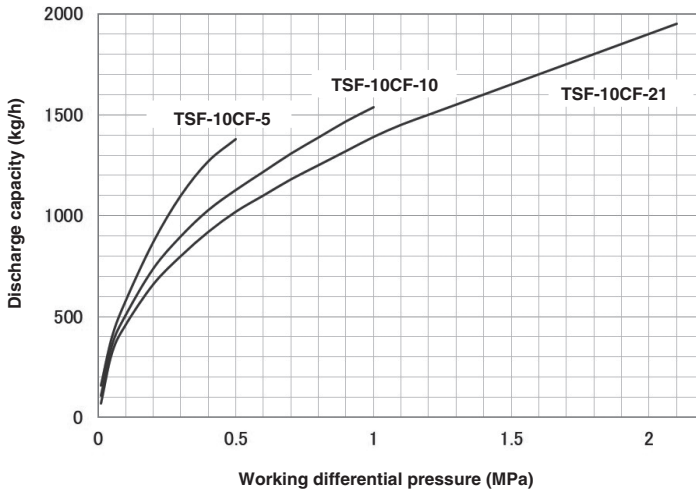

The discharge capacity shown in the charts on the above is the maximum value. In designing a system, select a steam trap with a sufficient safety factor (more than two times the regular level).